

# KC Series

SELF - P R I M E O P T I O N

## MagPrime Chamber

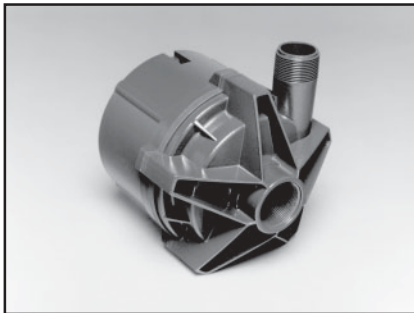

**MODULAR  
TECHNOLOGY**

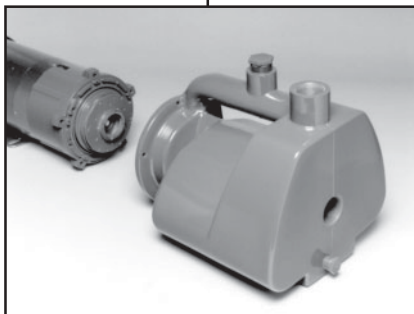

The MagPrime is a one-piece, molded high density polyethylene module which offers flexibility and self-prime operation to the KC 11 sealless magnetic drive pumps.

### Features

- Quick connect to KC 1145
- 15 ft. (4.5 m) lift in 2 minutes
- Locates above the liquid source
- Up to 1.4 specific gravity
- Temperature to 120°F (49°C)
- Excellent corrosion resistance
- Reduced maintenance

### Performance

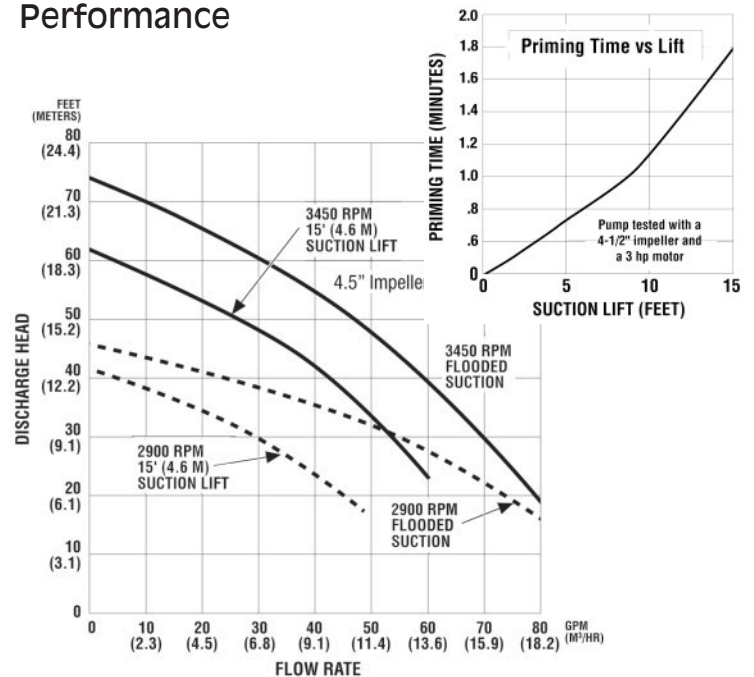

### Operation

- The MagPrime is connected to a KC 1145.
- A small amount of liquid is poured through the fill port to initially prime the chamber.
- The pump is started. Recirculating liquid creates a vacuum in the suction line, drawing air from the suction line and releasing it through the discharge outlet.
- When the liquid in the suction line reaches the pump inlet, the pump is "primed," and normal operation begins.

# Specifications

MODEL (CONSTRUCTION)	SUCTION DISCHARGE	IMPELLER SIZE		MAX. FLOW		MAX. HEAD		MOTOR DRIVE	
		inch	cm	3450 rpm gpm	2900 rpm m <sup>3</sup> /hr	3450 rpm ft	2900 rpm m	HP	kW
KC1145 (P, V)	1 1/2" FNPT	4-1/2	11.4	68	12.5	61	13	1 - 1.5	.55 - .75
	1 1/4" FNPT	4	10.2	48	9	50	10.5	1 - 1.5	.55 - .75
		3-1/2	8.9	44	8.5	42	9	.75 - 1	.37 - .55
		3	7.6	37	7	29	6	.75 - 1	.37 - .55

P - Polypropylene glass filled, carbon/PTFE, high purity ceramic and viton.

V - PVDF carbon filled, carbon/PTFE, high purity ceramic and viton.

# Dimensions

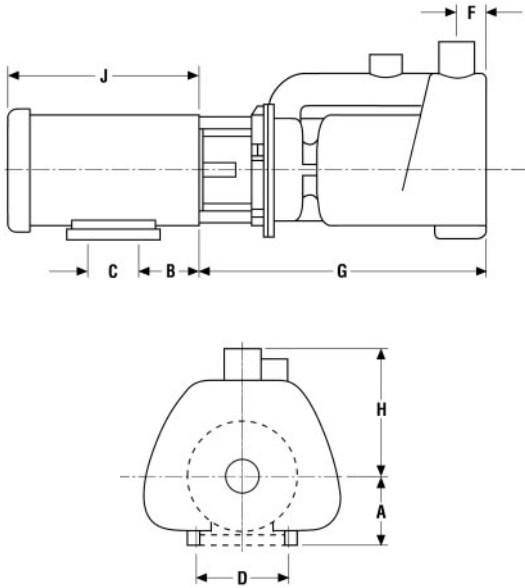

## With NEMA TEFC Motors (Inches)

MODEL	MOTOR FRAME	A	B	C	D	F	G	H	J*
KC11	56C	4-1/8	2-3/4	3	4-7/8	1-3/4	17	7-5/8	12-1/8
	145TC		5-1/2	5	5-1/2				13-1/4

## With IEC Motors (Millimeters)

MODEL	MOTOR FRAME	A	B	C	D	F	G	H	J*
KC11	80	105	50	100	125	44	432	194	230
	90		56	125	140				250

\*Differ by manufacturer

# Chemical Compatibility

Listed below are a few typical chemical applications for the MagPrime.

Legend:

E - 30 days of constant exposure. No damage detected.

G - Little or no damage after 30 days exposure.

F - Some effect after 7 days of constant exposure.

N - Not recommended for continuous use.

Note: First letter is at 68°F (20°C). The second letter is at 122°F (50°C), e.g. EG.

**Note:** While this information provides a reasonable representation of the effects of chemicals of listed materials, we do not guarantee favorable results and assume no liability in connection with its use.

Chemical	68°F (20°C)	122°F (50°C)	Chemical	68°F (20°C)	122°F (50°C)	Chemical	68°F (20°C)	122°F (50°C)
Acetic Acid, 5%	E	E	Chlorine, 10% moist	E	E	Hydrofluoric Acid, 45%	E	E
Ammonium Hydroxide, 5%	E	E	Chromic Acid, 50%	E	E	Nitric Acid, 50%	G	N
Chlorine, 10% in air	E	F	Formaldehyde, 10%	E	E	Sodium Hydroxide, 50%	E	E
Acetic Acid, 50%	E	E	Glacial Acetic Acid	E	E	Sulfuric Acid, 98%	G	G
Ammonium Hydroxide, 30%	E	E	Hydrochloric Acid, 35%	E	E			



## FINISH THOMPSON INC.

921 Greengarden Road • Erie, PA 16501-1591 U.S.A.  
 Ph 814-455-4478 • Fax 814-455-8518  
 Email [fti@finishthompson.com](mailto:fti@finishthompson.com) • [www.finishthompson.com](http://www.finishthompson.com)

Toll Free USA & Canada 1-800-934-9384  
 Literature I.D. No. - FT95-569F

