



AC 4 & 5 HORIZONTAL SERIES Sealed Metallic Centrifugal Pumps Installation and Maintenance Instructions

ASSEMBLY

PUMPS WITH MOTORS

1. No assembly required. Unpack the pump and motor and examine for any signs of shipping damage. If damage is detected, save the packaging and notify the carrier immediately.
2. Proceed to the "Installation" section of these instructions.

PUMPS WITHOUT MOTORS

Note: Do not remove shipping plug located in suction port of the pump until the pump is completely assembled onto the motor.

1. Unpack the pump and examine for any signs of shipping damage. If damage is detected, save packaging and notify the carrier immediately.
2. Place the motor on the fan cover. Align any set screw (item 9) with key slot in motor shaft. Place the aluminum motor adapter (item 8) onto the motor rabbet. Position the slot (shaft sleeve set screw access hole) in motor adapter with the top of the motor. Line up the bolt holes in the motor adapter with the bolt holes in the motor face. Install (4) bolts and lock washers (items 10,11). Securely tighten.
3. Through the top and bottom access holes, tighten securely two of the four set screws on the shaft adapter (item 6). You will need an 1/8" Allen wrench for this.
4. Remove the screw from the shipping plug and then remove the plug from the suction port. Rotate the motor fan until you can tighten the two remaining set screws on the shaft adapter.
5. Rotate the motor fan by hand and check for impeller rubbing. If the impeller rubs loosen the shaft adapter set screws and adjust the impeller accordingly. Retighten the shaft adapter set screws.
6. Proceed to the "Installation" section of these instructions.

INSTALLATION

MOUNTING

Motor or base plate must be securely fastened.

PIPING TO AND FROM THE PUMP

- Always support the piping near the pump to minimize stress and strain on the pump's casing.
- Minimize frictional losses by increasing the suction piping size by one diameter.
- Use a minimal number of bends on suction piping, keeping any bends beyond a distance of ten pipe diameters from the pump.
- Install shut off valve on the suction line and flow control valve in the discharge line. Place the valves beyond a distance of ten pipe diameters from the pump.
- Ensure that the piping is leak free.
- Position the pump as close to the liquid source as possible.
- Maintain a flooded suction at all times or prime the pump and maintain prime at all times.

⚠ CAUTION: Suction prime must be maintained at all times. Running the pump dry will cause damage to pump components. To protect the pump if prime is lost, use a pressure switch on the discharge, a vacuum switch on the suction, or a motor minder to monitor motor current draw.

PUMPING LIQUIDS THAT MAY SOLIDIFY OR CRYSTALLIZE:

Add a flush system to the pump's piping to prevent accumulation of material inside the pump. Install water inlet and outlet valves as shown in Figure 1. Refer to the "Operation" section of these instructions for the flush procedure.

ELECTRICAL CONNECTIONS

1. Perform the motor wiring according to NEC requirements and local electrical codes.
2. Wire the motor for clockwise rotation when facing the fan end of the motor.
3. To verify correct rotation of the motor:

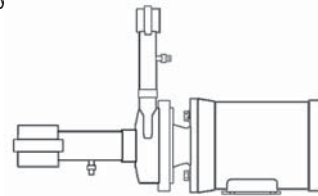

Figure 1

- a. Install the pump into the system.
- b. Fully open the suction and discharge valves.
- c. Allow fluid to flow into the pump. Do not allow the pump to run dry. Running the pump dry can damage internal parts.
- d. Jog the motor (allow it to run for only 1-2 seconds) and observe the rotation of the motor fan. Refer to the directional on the arrow pump if needed.

NOTE: A pump running backwards will pump, but at a greatly reduced rate.

OPERATION

FLOODED SUCTION SYSTEMS

1. Fully open the suction and discharge valves.
2. Start the pump and verify liquid is flowing. If there is no liquid flow, refer to the "Troubleshooting" section of these instructions.
3. Adjust the flow rate and pressure by regulating the discharge valve.

⚠ CAUTION: Never attempt to adjust the liquid flow with the suction valve. Limiting suction will damage pump components.

FLUSHING SYSTEMS EQUIPPED WITH FLUSH VALVES:

1. Fully close the suction and discharge valves.
2. Connect the water supply to the water inlet valve and connect a drain hose to water outlet valve.
3. Turn on the water supply and open the inlet and outlet valves. Flush the system until the pump has been cleared of any material buildup (usually approximately 5 minutes).
4. Close the water inlet and outlet valves and turn off water supply.

MAINTENANCE

DISASSEMBLY

1. Disconnect power. Remove electrical wiring.
2. Close the suction and discharge valves and disconnect all piping.
3. Loosen and remove the nut on the V-clamp stud. Remove the V-clamp (item 2) and the impeller housing (item 1). Note V-clamp stud and discharge spout location for reassemble alignment.
4. Remove the motor fan cover and fan. Secure the motor shaft to prevent it from turning and unthread the impeller.

NOTE: Shaft adapter threads are coated with Loctite Threadlocker #262 to prevent the impeller from spinning off if the motor is inadvertently wired for incorrect rotation. If necessary follow Loctite's recommendations for loosening the threadlocker #262.

5. Remove the seal spring retainer, spring, and the rotating seal component from the shaft adapter. Remove the backhead (item 7) from the pump. Remove the stationary part of the seal from the backhead.
6. If the motor is being replaced, proceed to step 7. If the seal is being replaced, **do not** loosen or remove the shaft adapter (item 6) from the motor shaft. Proceed to step 3 of the reassembly instructions
7. Remove the four bolts holding the motor adapter/mounting plate assembly (items 8 & 15) to the motor and remove the motor adapter. Loosen all four setscrews and remove the shaft adapter.
8. Inspect all parts for wear and replace as required. Note the finish on the shaft adapter where the rotating seal boot is located. If damaged or not smooth, replace the shaft adapter.

REASSEMBLY

1. Install the shaft adapter (item 6) onto the motor shaft. Be sure one of the setscrews is protruding into the motor shaft keyway slot, but do not tighten any setscrews yet.
2. Install the motor adapter/mounting plate assembly (8 & 15) with setscrews access slots at 12 and 6 location, and tighten all four bolts.
3. Lubricate the outer boot on the stationary part of the seal with a chemically compatible lubricant, and press into the backhead (item 7) until it is fully seated. The polished seal surface should be facing away from the motor.

NOTE: To keep the polished surface of the seal face clean, use a piece of cardboard to protect the seal face during installation.

4. Insert the backhead (item 7) into the motor adapter (item 8) bore and press into place.

If the shaft adapter was not loosened or removed, go to step 5. If replacing the shaft adapter, firmly hold the backhead toward the motor, and adjust the shaft adapter until the shoulder is .843 (27/32) inches from the stationary seal face (see figure 2). Tighten all four setscrews with a T wrench through the access slots in the motor adapter.

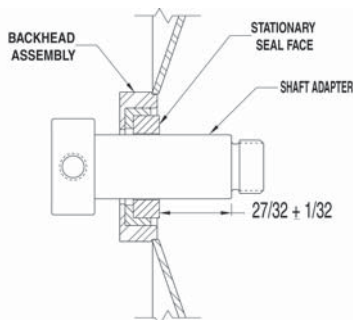

Figure 2

5. Lubricate the inside of the rotating seal component with a chemically compatible lubricant and carefully slide it over the shaft adapter with a rotating face pointing at the motor (as shown in figure 3).

NOTE: Rotating seal must be completely seated against the stationary seal face.

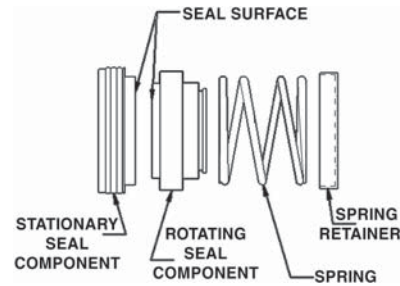

Figure 3

6. Place the seal spring and spring retainer over the shaft adapter.
NOTE: To prevent spinning the impeller off in case the motor is wired for incorrect rotation, it is recommended to coat the shaft adapter threads with Loctite Threadlocker #262.
7. Holding the motor shaft firmly, thread the impeller onto the shaft adapter until it stops at the adapter shoulder.
8. Lubricate the housing o-ring (item 3) with chemically compatible lubricant, and install onto the backhead. Install the impeller housing (item 1), the V-clamp (item 2), and the nut onto the V-clamp stud. Verify the V-clamp stud and housing discharge orientation and tighten the V-clamp. Firmly tap the V-clamp to seat it in several places and retighten the V-clamp nut.
9. Rotate the motor shaft by hand to verify there is no rubbing. Replace the motor fan and fan cover. Reinstall the pump into the system.

TROUBLESHOOTING

NO OR INSUFFICIENT FLOW

1. Pump not primed.
2. Closed valve.
3. Viscosity too high.
4. Air leaks in suction piping.
5. Discharge head higher than anticipated.
6. Suction lift too high or insufficient NPSH.
7. Check for clogged suction line.

INSUFFICIENT PRESSURE

1. Air or gas in liquid.
2. Impeller diameter too small.
3. Discharge head higher than anticipated.
4. Motor speed insufficient (too low) or motor rotation incorrect.

LOSS OF PRIME

1. Leaking suction line.
2. Foot valve or suction opening not submerged enough.
3. Foot valve too small or leaking.
4. Air or gas in liquid.
5. Foreign matter in impeller.

EXCESSIVE POWER CONSUMPTION

1. Head lower than rating. Excessive flow.
2. Specific gravity or viscosity of liquid is too high.

EXCESSIVE VIBRATION

1. Loose piping or bolts.
2. Pump cavitating from improper suction or feed.

AC4 EXPLODED VIEW

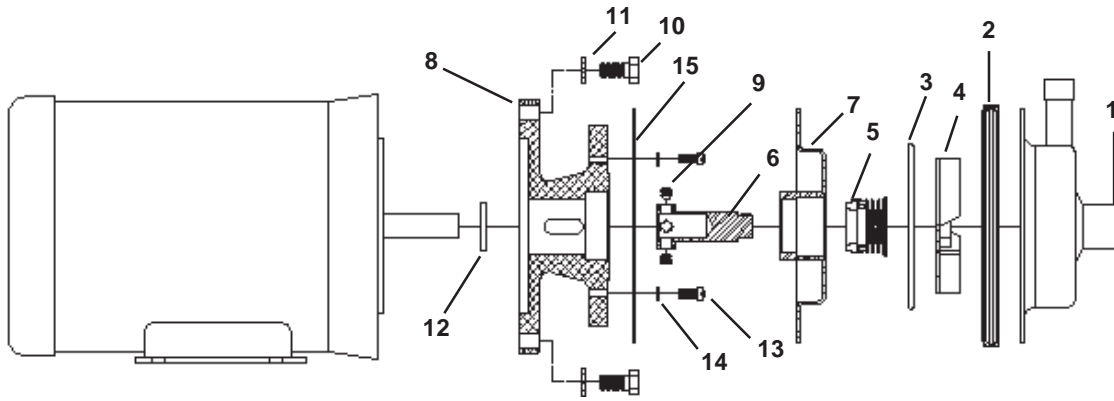

AC5 EXPLODED VIEW

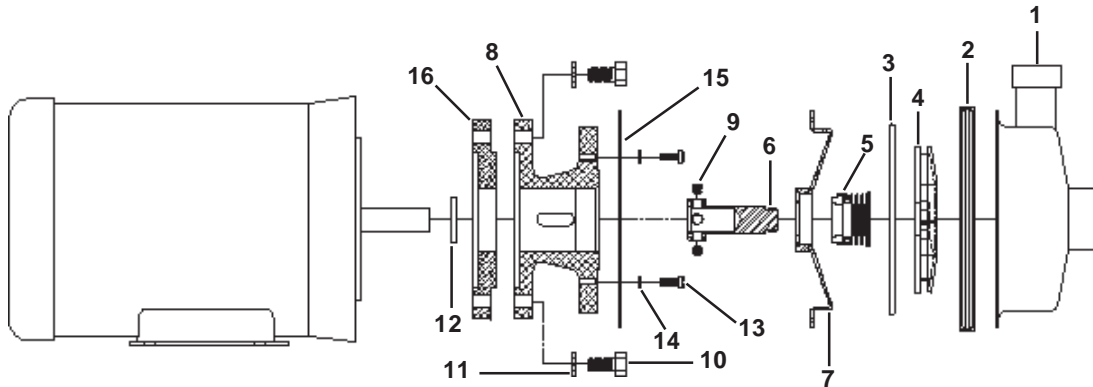

Item	Qty	Description	AC4 Part Number	AC5 Part Number
1	1	Impeller Housing AC4 3/4" x 1/2" AC5 1 1/4" x 3/4" AC5 1 1/2" x 1 1/4" AC5 2" x 1 1/2" AC5H 1/2" x 1/4" (high head)	A102106-1 (universal FNPT & BSP*)	AC5S FNPT (BSP)* A102113-1(2) A102112-1(3) A102133-1(2) A102120-1(2) AC5R FNPT (BSP)* A102112-2(4) A102133-3(4)
2	1	V-Clamp	J102947	J102947 J102947
3	1	O-Ring Viton EPDM Teflon	J102946 J103004 J103042	J102960 J102960 J103003 J103003 J103043 J103043
4	1	Impeller AC4/AC5R 3" AC4 3 1/4" AC4/AC5R 3 1/2" AC5R 3 3/4" AC5R 4 1/2" AC5 4" x 3/8" vane AC5 4 1/4" x 3/8" vane AC5 4 1/2" x 3/8" vane AC5 4 3/4" x 3/8" vane AC5 4" x 1/4" vane AC5 4 1/4" x 1/4" vane AC5 4 1/2" x 1/4" vane AC5 4 3/4" x 1/4" vane AC5H 4 3/4" x 1/8" vane (high head)	A102105-1 A102105-2 A102105-3	A102105-1 A102105-2 A102105-3 A102105-4 A102105-5 A102114-9 A102114-10 A102114-11 A102114-12 A102114-1 A102114-2 A102114-3 A102114-4 A102183

*To order a housing with BSP threads, substitute the number following the dash with the number in the parentheses.

Item	Qty	Description	AC4 Part Number	AC5 Part Number
5	1	Seal 3/4" Carbon/Ceramic/Viton Seal 3/4" Carbon/Ceramic/EPDM Seal 3/4" Carbon/Ceramic/Teflon Seal 3/4" Silcarb./Silcarb./Viton Seal 3/4" Silcarb./Silcarb./EPDM Seal	J102957-1 J102957-2 J103081 J103066 J103067	J102957-1 J102957-2 J103081 J103066 J103067
6	1	Shaft Adapter w/set screws 56C Frame 71-B14 Frame 80 Frame 90 Frame	A102895 A102896	A102895 A102896 A102897 A102898
7	1	Backhead	A102110-1	A102121-1
8	1	Motor Adapter 56C Frame 71-B14 Frame 80 Frame 90 Frame	M102049-1 M102049-2	M102049-1 M102049-2 M102049-3 M102049-4
9	4	1/4-20 x 1/4" Cup Point Set Screw	J100220	J100220
10	4	Hex Head Cap Screw 3/8-16 x 1" (56C Frame) M6 x 25 mm (71-B14 & 80 Frame) M8 x 40 mm (90 Frame)	J100114 J103456	J100114 J103456 J102760
11	4	Lock Washer 3/8" (56C & 90 Frame) 1/4" (71-B14 & 80 Frame)	J100115 J100672	J100115 J100672
12	1	Slinger Ring 56C Frame 71-B14 Frame 80 Frame 90 Frame	M102064-1 M102064-2	M102064-1 M102064-2 M102064-3 M102064-4
13	4	Cap Screw Fillister Head	J100932	J100932
14	4	#10 Lock Washer	J100824	J100824
15	1	Mounting Plate	J103389-1	J103389-1
16	1	Metric Motor Adapter (90 Frame only)		M102129

WARRANTY

Finish Thompson, Inc (manufacturer) warrants this product to be free of defects in materials and workmanship for a period of 180 days from date of purchase by original purchaser. If a warranted defect, which is determined by manufacturer's inspection, occurs within this period, it will be repaired or replaced at the manufacturer's option, provided (1) the product is submitted with proof of purchase date and (2) transportation charges are prepaid to the manufacturer. Liability under this warranty is expressly limited to repairing or replacing the product or parts thereof and is in lieu of any other warranties, either expressed or implied. This warranty does apply only to normal wear of the product or components. This warranty does not apply to products or parts broken due to, in whole or in part, accident, overload, abuse, chemical attack, tampering, or alteration. The manufacturer accepts no responsibility for product damage or personal injuries sustained when the product is modified in any way. If this warranty does not apply, the purchaser shall bear all cost for labor, material and transportation.

Manufacturer shall not be liable for incidental or consequential damages including, but not limited to process down time, transportation costs, costs associated with replacement or substitution products, labor costs, product

installation or removal costs, or loss of profit. In any and all events, manufacturer's liability shall not exceed the purchase price of the product and/or accessories.

Call our toll free Technical Service Hot Line, 1-800-888-3743, if you have any questions regarding product operation or repair.

ORDERING SPARE PARTS

Spare parts can be ordered from your local distributor. Always refer to pump model number to avoid error.

OTHER FTI PRODUCTS

Drum Transfer Pumps are available in sanitary construction, stainless steel, polypropylene and CPVC.

Portable Mixers for turbine mixing and blending. Available in 316 stainless steel construction.

Sealed Centrifugal Pumps in polypropylene and CF PVDF come with a wide variety of sealing materials. NEMA or IEC motors.

Sealless Mag Drive Centrifugal Pumps in polypropylene and CF PVDF. NEMA or IEC motors.



FINISH THOMPSON INC.

921 Greengarden Road • Erie, PA 16501-1591 U.S.A.
Ph 814-455-4478 • Fax 814-455-8518
Email fti@finishthompson.com • www.finishthompson.com

Tech Service: 800-888-3743
P/N J103334, Rev. 9, 1/04
Lit. I.D. No. FT98-718I

