



KC11 SERIES Sealless Non-Metallic Centrifugal Pumps

Installation & Maintenance Instructions

ASSEMBLY

Unpack pump from carton and check for shipping damage.

ATEX COMPLIANT PUMPS

All assembly, installation, and maintenance instructions are the same as standard pumps with the exceptions noted on page 4 under "Additional Information for the Use of ATEX Compliant Pumps."

PUMPS WITH MOTORS

Remove shipping caps and inserts from suction and discharge, and proceed to installation instructions.

PUMPS WITHOUT MOTORS - 145TC

1. Remove pump end assembly from box.
2. Remove two Phillips pan head screws (item 7) and hex nuts (item 9) from impeller housing. Then remove wet end assembly from motor adapter.
3. Remove hardware package from box.
4. Install motor adapter (item 4) onto motor. Place 3/8" flat washers (item 15) between the motor adapter and the motor. Flat washers must be aligned with motor adapter mounting holes. Align motor adapter with motor rabbet and secure with socket head cap screws (item 10) and lock washers (item 11). See figure 6.
5. Continue to step 5 of ASSEMBLY - PUMPS WITHOUT MOTORS - ALL OTHER MOTORS.

ALL OTHER MOTORS

1. Remove pump end assembly from box.
- ⚠ CAUTION: Strong magnets present.** Keep metal objects and metallic chips/particles away from pump components.
2. Remove two Phillips pan head screws (item 7) and hex nuts (item 9) from impeller housing, and remove wet end assembly from motor adapter.
3. Remove hardware package from box.
4. Install motor adapter (item 4) onto motor and secure with socket head cap screws (item 10) and lock washers (item 11). Refer to Figure 6.
5. Coat the motor shaft with anti-seize compound. Slide drive magnet assembly (item 5) onto motor shaft keeping shaft key in place. Installation dimension from front of drive magnet assembly to face of motor adapter is $.180 \pm .010$ inches ($4.57 \text{ mm} \pm .25 \text{ mm}$). Tighten 2 set screws (item 5A) with a 3/16" "T" handle Allen wrench to 228 in-lbs

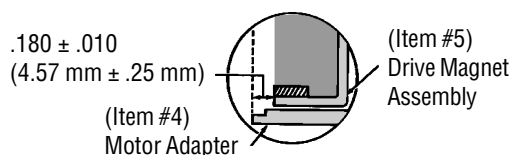

Figure 1

(25.8 N-m). A spacing tool is available for setting proper dimension (p/n A103188). See Figure 1.

IMPORTANT: Verify the tightness of the set screws in the drive magnet assembly prior to operation.

6. Install the wet end assembly by grasping the discharge with your right hand the "fins" (marked 3 and 5 in figure 2) with your left hand. Carefully align the wet end with the motor adapter and allow the magnets to pull it into place.

⚠ WARNING: Components can slam together from strong magnets. Do not allow fingers to get between the wet end and the motor adapter.

Align mounting holes and install 5 Phillips pan head screws (item 7) and hex nuts (item 9). Hand tighten screws to 30 in-lbs. (3.34 N-m) of torque using the pattern shown in figure 2.

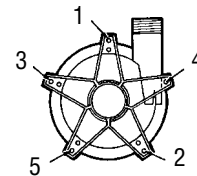

Figure 2

Note: Plastic pumps will expand and contract with temperature so periodically check and hand tighten the Phillips head pan screws.

7. Remove the two-piece shipping plug and insert from the suction of the housing after the pump has been placed into the system and just before you attach the piping. Keep the shipping plug for use when disassembling the pump. Always use the shipping plug when assembling or disassembling the wet end to protect the internal parts.
8. Install pump into system according to installation instructions below.

INSTALLATION MOUNTING

Motor or base plate should be securely fastened.

PIPING

1. Support piping near pump to eliminate any strain on pump casings.
2. To minimize head loss from friction:
 - a. Increase pipe size by 1 diameter.
 - b. Use minimal number of pipe bends.
3. Keep bends a minimum of 10 pipe diameters from suction and discharge.
4. Position pump as close to liquid source as possible.
5. Maintain a flooded suction.
6. Ensure that piping does not leak.

- Install valves on suction and discharge lines (a minimum of 10 pipe diameters from pump).
- For units in a suction lift system, install appropriate piping in the discharge to allow priming of pump.
- The suction valve should be fully open to avoid restricting suction flow.
IMPORTANT: To protect the pump if prime is lost, use one of the following: (1) pressure switch on the discharge; (2) vacuum switch on the suction; (3) a motor minder to monitor motor current.
- When pumping liquids which may solidify or crystallize, a flush system should be added to the piping. See Figure 3. Install water inlet and outlet valves as shown.

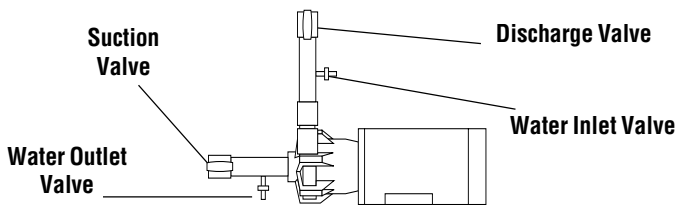

Figure 3

ELECTRICAL

Install motor according to NEC requirements and local electrical codes.

IMPORTANT: To verify correct motor rotation: (1) Install pump into system. (2) Fully open suction and discharge valves. (3) Allow fluid to flow into the pump. Do not allow pump to run dry (PTFE and ceramic bushings cannot be run dry without damage to pump components). (4) Jog motor (allow it to run for one or two seconds) and observe rotation of motor fan. Correct rotation is clockwise as viewed from motor fan. Refer to directional arrow on pump.

OPERATION

FLOODED SUCTION SYSTEM

- Fully open suction and discharge valves.
- Start the pump and check liquid flow. If no flow, see troubleshooting section.
- Adjust flow rate and pressure by regulating discharge valve. Do not attempt to adjust flow with the suction valve.

SUCTION LIFT SYSTEM

- Fully open suction and discharge valves.
- Prime system by filling priming chamber and suction line with liquid to be pumped. Allow time for trapped air to work its way out.
- Start the pump and check liquid flow. If no flow, see troubleshooting section.
- Adjust flow rate and pressure by regulating discharge valve. Do not attempt to adjust flow with the suction valve.

FLUSH SYSTEMS

- Fully close suction and discharge valves.
- Connect water supply to water inlet valve.
- Connect drain hose to water outlet valve.
- Open inlet and outlet valves and flush system until pump is clean (approximately 5 minutes).

MAINTENANCE

DISASSEMBLY

- Disconnect power. Remove electrical wiring and mounting bolts to floor or base plate.
- Close suction and discharge valves, and disconnect piping.
- Install the two-piece shipping plug into the suction of the housing. Remove the 5 Phillips pan head screws and hex nuts (items 7 and 9).
- Securely clamp or hold motor in place. Remove wet end by gripping the discharge with your right hand while gripping the two fins marked 3 and 5 in figure 2. With a tight grip, pull the wet end straight out of the motor adapter using one quick motion.

WARNING: Components can slam together from strong magnets. Keep fingers away from area between housing and motor adapter.

- To disassemble wet end, remove the 4 Phillips head screws (item 13).
- Remove impeller housing (item 1) from barrier (item 3), and pull out the impeller assembly (item 2). Remove o-ring (item 6). To remove drive magnet assembly (item 5), insert a 3/16" hex wrench in the access hole on motor adapter top and loosen the 2 set screws (item 5A). Remove the drive assembly from the motor shaft.

To remove the drive magnet assembly, use a hook-type puller through the 1/2" hole or a yoke-type puller through the 3/8" threaded holes. Pull the drive by pushing off of the end of the motor's shaft. Always coat the motor shaft with an anti-seize compound prior to reinstalling.

CAUTION: Strong magnets present. Keep metal objects and metallic chips/particles away from pump components.

EXAMINATION

- Check impeller drive bushing (item 2A), thrust ring (item 2B), ceramic thrust rings and shaft for cracks, chips, scoring or excess wear (See Figure 4). Replace as required.

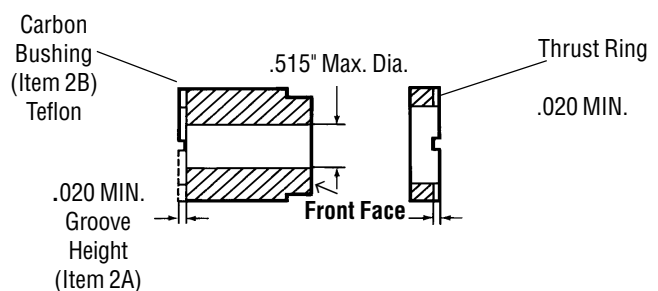

Figure 4

- Check for loose magnets on drive assembly or rubbed areas on impeller or barrier assemblies. Contact your distributor or FTI Technical Service if a problem is found.

BUSHING AND THRUST RING REPLACEMENT

1. To remove the bushing, place the impeller assembly (item 2) in an arbor press. Insert a 3/4" diameter plastic or wood shaft through the eye of the impeller and press bushing out. Refer to Figure 5.

Figure 5

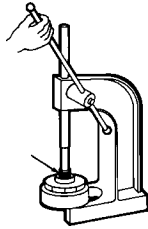

2. To replace the bushing, place the top of the impeller on an arbor press with the thrust ring (item 2B) face down. Insert the front of the bushing (see figure 4) into the center of the impeller, aligning the flat on the bushing with the flat in the impeller. Press into place until the rear of the bushing (the slotted end) is .855 below the bottom of the impeller. An installation tool (P/N M102392) is available to aid in proper installation.
3. The impeller thrust ring (item #2B) can be removed from the impeller body (item #2) by gently pulling the ring from the impeller cover.
4. To replace the thrust ring, align the flat on the ring (grooved side up) with the flat on inside of the impeller assembly (item 2), and press into place.

Note: Protect thrust ring face with wood or plastic and avoid tilting of the ring.

REASSEMBLY

WET END SUBASSEMBLY

1. Install o-ring (item 6) onto lip of barrier assembly (item 3).
2. Make sure impeller assembly is free of metal chips. Position impeller assembly (item 2) onto shaft and lower into barrier.
3. Lubricate the o-ring with a chemically compatible lubricant and install impeller housing (item 1) onto barrier, making sure to align matching bosses on barrier with recesses in impeller housing. Install 4 Phillips head screws and tighten carefully, do not overtighten.
4. For reassembly of wet end to motor, refer to assembly section, page 1, steps 6- 8.

SAFETY PRECAUTIONS FOR ATEX PUMPS

⚠ WARNING: ATEX pumps must use a power monitor to help protect against running dry, closed discharge valve, and decoupling. Any of these conditions could lead to a rise in surface temperature of the pump.

⚠ WARNING: The pump must be checked for leaks on a regular basis. If leaks are noticed, the pump must be repaired or replaced immediately.

⚠ WARNING: The pump must be cleaned on a regular basis to avoid dust build up greater than 5 mm.

⚠ CAUTION: Proper o-ring material must be chosen based on the fluid being pumped. Improper material selection could lead to swelling and a possible source of leaks. This is the responsibility of the end user.

TEMPERATURE CLASSIFICATION

The surface temperatures of the KC ATEX Series pumps depend upon the temperature of the fluid being pumped. The chart below lists different fluid temperatures and the corresponding pump surface temperatures.

Fluid Temperature	Maximum Surface Temperature	Temperature Class	Maximum Allowable Surface Temperature
80°F (27°C)	122°F (50°C)	T6	85°C
185°F (85°C)	192°F(89°C)	T4	135°C
220°F (104°C)	248°F(120°C)	T3	200°C

TROUBLESHOOTING

NO DISCHARGE

1. Pump not primed.
2. Discharge head too high.
3. Suction lift too high. Insufficient NPSH.
4. Closed valve.
5. Viscosity too high (magnets uncoupled).

INSUFFICIENT DISCHARGE

1. Air leaks in suction piping.
2. Discharge head higher than anticipated.
3. Suction lift too high or insufficient NPSH. Check also for clogged suction line or foot valve.
4. Foot valve too small.
5. Foot valve or suction opening not submerged enough.

INSUFFICIENT PRESSURE

1. Air or gasses in liquid.
2. Impeller diameter too small.
3. Discharge head higher than anticipated.

LEAK AT IMPELLER HOUSING

1. O-ring pinched or chemically attacked. Replace with new o-ring.
2. Phillips pan head screws improperly or overtightened. Install according to assembly instructions.
3. Check motor adapter for cracks.
4. Total overall pressure too high. Do not exceed 35 psi inlet and outlet pressure.

LOSS OF PRIME

1. Leaking suction line.
2. Suction lift too high or insufficient NPSH.
3. Air or gasses in liquid.
4. Foreign matter in impeller.
5. Leaking foot valve.

EXCESSIVE POWER CONSUMPTION

1. Head lower than rating. Pumps too much liquid.
2. Specific gravity or viscosity of liquid pumped is too high or higher than that defined in application.

VIBRATION

1. Excess bearing wear.
2. Drive magnet uncoupled.
3. Loose magnet.
4. Pump Cavitating

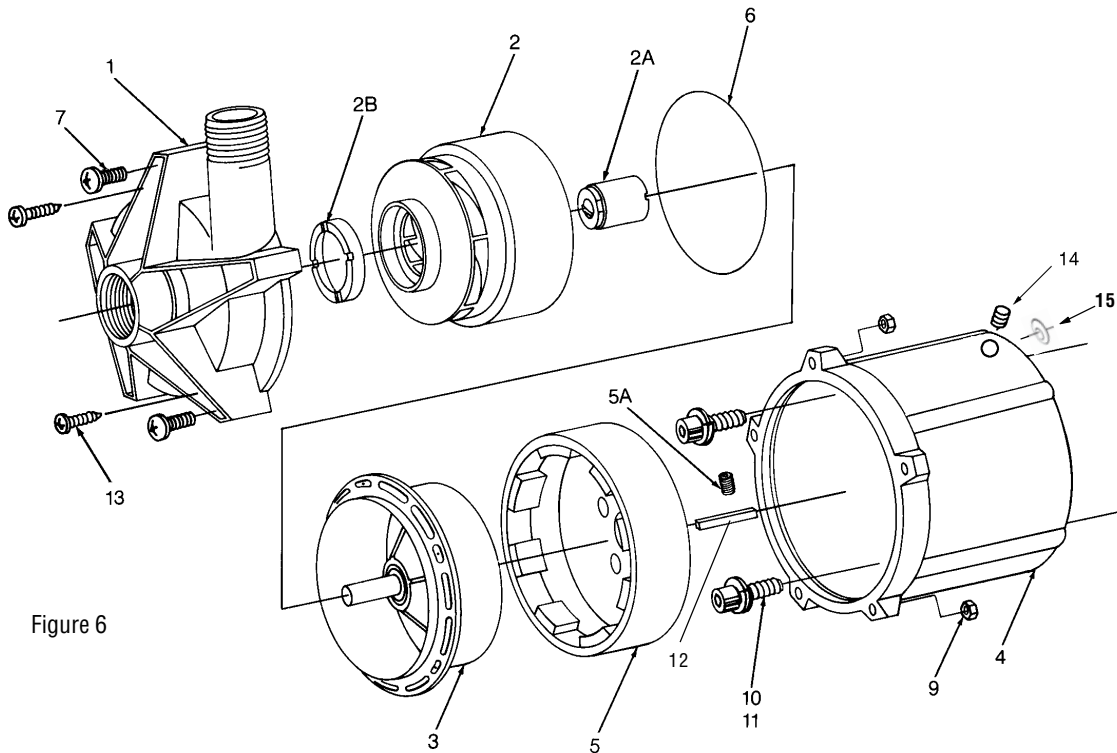

Figure 6

Item	Qty.	Description	Part Number	
			Polypropylene	PVDF & ATEX
1	1	Impeller Housing Assembly - NPT (includes Ceramic Thrust Ring)	A101014-1	A101014-2
1	1	Impeller Housing Assembly - BSP (includes Ceramic Thrust Ring)	A101014-4	A101014-5
2	1	Impeller Assembly w/carbon bushing 4-1/2" 4" 3-1/2" 3"	A101928 A101929 A101930 A101931	A101936 A101937 A101938 A101939
2	1	Impeller Assembly w/PTFE bushing 4-1/2" 4" 3-1/2" 3"	A101932 A101933 A101934 A101935	A101940 A101941 A101942 A101943
2	1	Impeller Assembly w/ceramic bushing 4-1/2" 4" 3-1/2" 3"	A103106 A103107 A103108 A103109	A103110 A103111 A103112 A103113
2A1	1	Carbon Bushing Only	J100977	
2A2	1	PTFE Bushing Only (Optional)	J100977-1	
2A3	1	Ceramic Bushing (Optional)	J100977-2	
2B	1	PTFE Thrust Ring Only	J101606	
3	1	Barrier Assembly (incl. Ceramic Shaft & Thrust Ring)	A101008-1	A101008-2
4	1	Motor Adapter (U.S.) Motor Adapter (Metric) 80 Frame Motor Adapter (Metric) 80 Frame ATEX Motor Adapter (Metric) 90 Frame Motor Adapter (Metric) 90 Frame ATEX	M101629-1 M101629-2 M101629-4 M101629-3 M101629-5	

	1	Wet End Only (incl. items 1, 2, 3, 6 & 13)	SEE PRICE SHEET	
--	---	-----------------------------------------------	-----------------	--

Item	Qty.	Description	Part Number PP, PVDF, ATEX
5	1	Drive Magnet Assembly 56C Motors (ATEX N/A) 145TC Motors (ATEX N/A) 80 Frame Motors 90 Frame Motors	A101019-1 A101019-2 A101019-3 A101019-4
5A	2	Set Screw	J101084
6	1	Housing O-Ring -Viton -EPDM	J102774 J102775
7	5	Philips Pan Head Screws	J100998
9	5	Hex Nut	J100321
10	4	Socket Head Cap Screws -U.S. (ATEX N/A) -Metric (80Fr.) -Metric (90Fr.)	J101000 J101080 J101081
11	4	Lockwashers -U.S. (145TC) (ATEX N/A) -Metric (80Fr.) -Metric (90Fr.)	J100128 J100672 J101083
12	1	Shaft Key US 3/16 (ATEX N/A) 80 frame 6mm 90 frame 8mm	M101708 M101647 M101749
13	4	Phillips Head Screws	J101020
14	1	Plug for Access Hole	J102878
15	4	3/8 SS flat washer	J100128

WARRANTY

Finish Thompson, Inc (manufacturer) warrants this product to be free of defects in materials and workmanship for a period of 180 days from date of purchase by original purchaser. If a warranted defect, which is determined by manufacturer's inspection, occurs within this period, it will be repaired or replaced at the manufacturer's option, provided (1) the product is submitted with proof of purchase date and (2) transportation charges are prepaid to the manufacturer. Liability under this warranty is expressly limited to repairing or replacing the product or parts thereof and is in lieu of any other warranties, either expressed or implied. This warranty does apply only to normal wear of the product or components. This warranty does not apply to products or parts broken due to, in whole or in part, accident, overload, abuse, chemical attack, tampering, or alteration. The manufacturer accepts no responsibility for product damage or personal injuries sustained when the product is modified in any way. If this warranty does not apply, the purchaser shall bear all cost for labor, material and transportation.

Manufacturer shall not be liable for incidental or consequential damages including, but not limited to, process down time, transportation costs, costs associated with replacement or substitution products, labor costs, product installation or removal costs, or loss of profit. In any and all events, manufacturer's liability shall not exceed the purchase price of the product and/or accessories.

CHEMICAL REACTION DISCLAIMER

The user must exercise primary responsibility in selecting the product's materials of construction, which are compatible with the fluid(s) that come(s) in contact with the product. The user may consult Finish Thompson, Inc. (manufacturer) and a manufacturer's representative/distributor agent to seek a recommendation of the product's material of construction that offers the optimum available chemical compatibility.

However neither manufacturer nor agent shall be liable for product damage or failure, injuries, or any other damage or loss arising out of a reaction, interaction or any chemical effect that occurs between the materials of the product's construction and fluids that come into contact with the product's internals.

ORDERING OF SPARE PARTS

Spare parts can be ordered from your local distributor. Always refer to pump model number to avoid error.

OTHER FINISH THOMPSON PRODUCTS

Drum Transfer Pumps are available in sanitary construction, stainless steel, polypropylene, PVDF and CPVC. Flows to 40 gpm, discharge heads to 300 feet and viscosities to 100,000 cP.

Portable Mixers for turbine mixing and blending handle viscosities to 1,000 cP with gentle, non-vortexing circulation. Available in 316 stainless steel construction.

Centrifugal Pumps in polypropylene, PVDF, and 316 SS are offered in mag drive sealless or mechanical seal models. Pumps are capable of 330 gpm, up to 325 feet discharge head, and 220°F (104°C) maximum. For more information, contact Finish Thompson Inc. or see our web site at www.finishthompson.com.

Call our toll free **Technical Service Hot line, 1-800-888-3743**, if you have any questions regarding product operation or repair.



FINISH THOMPSON INC.

921 Greengarden Road • Erie, PA 16501-1591 U.S.A.

Ph 814-455-4478 • Fax 814-455-8518

Email fti@finishthompson.com • www.finishthompson.com

J102315, Rev. 11,2/9/05
Literature I.D. No. FT97-642H

